

SO²FIE™

USER MANUAL

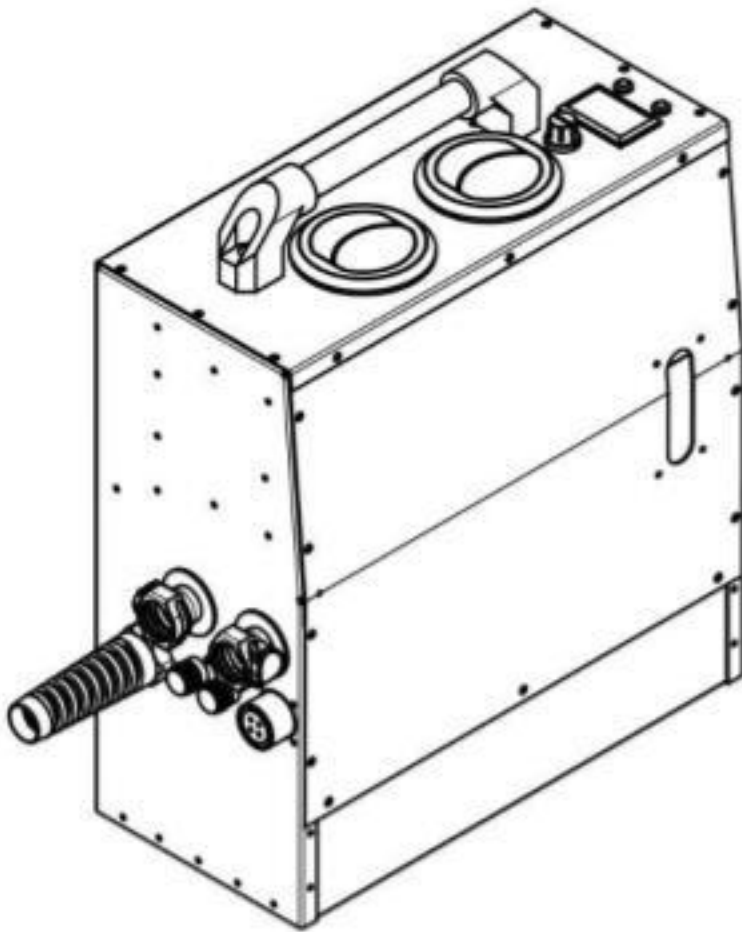

Table of Contents

Introduction.....	3
Overview.....	4 - 6
Safety Information.....	7 & 8
System Components.....	9 & 10
Operating Instructions.....	11
Automatic Operational Sequences.....	12
Maintenance & Care.....	13
Troubleshooting.....	14 & 15
Technical Specifications.....	16 - 19
Warranty Information.....	20
Contact Information.....	21

Introduction

The Sofie™ uses patented liquid technology to remove the heat from the cabin to a heat exchanger in the aft fuselage of the aircraft by means of two 3/8 inch hoses. The main unit can be placed anywhere in the forward cabin. The Sofie™ main module goes anywhere in the aircraft cabin where cooling is most needed. Two adjustable vents at the top of the Sofie™ Module direct cool air flow direction. Since there is no cool air ducting, the system is very efficient and provides the cooling capacity of larger systems. The air conditioner capacity and current draw is continuously adjustable to meet the requirement of most aircraft electrical systems, from single engine piston to turbine aircraft. A Scoop is recommended for this unit. The Sofie™ can be used on pressurized aircraft. **The Sofie™ System is not FAA certified.** It is intended as a non-permanent installation that is removed from the aircraft for annual inspections and is subsequently replaced in the aircraft when needed.

Main Module Overview

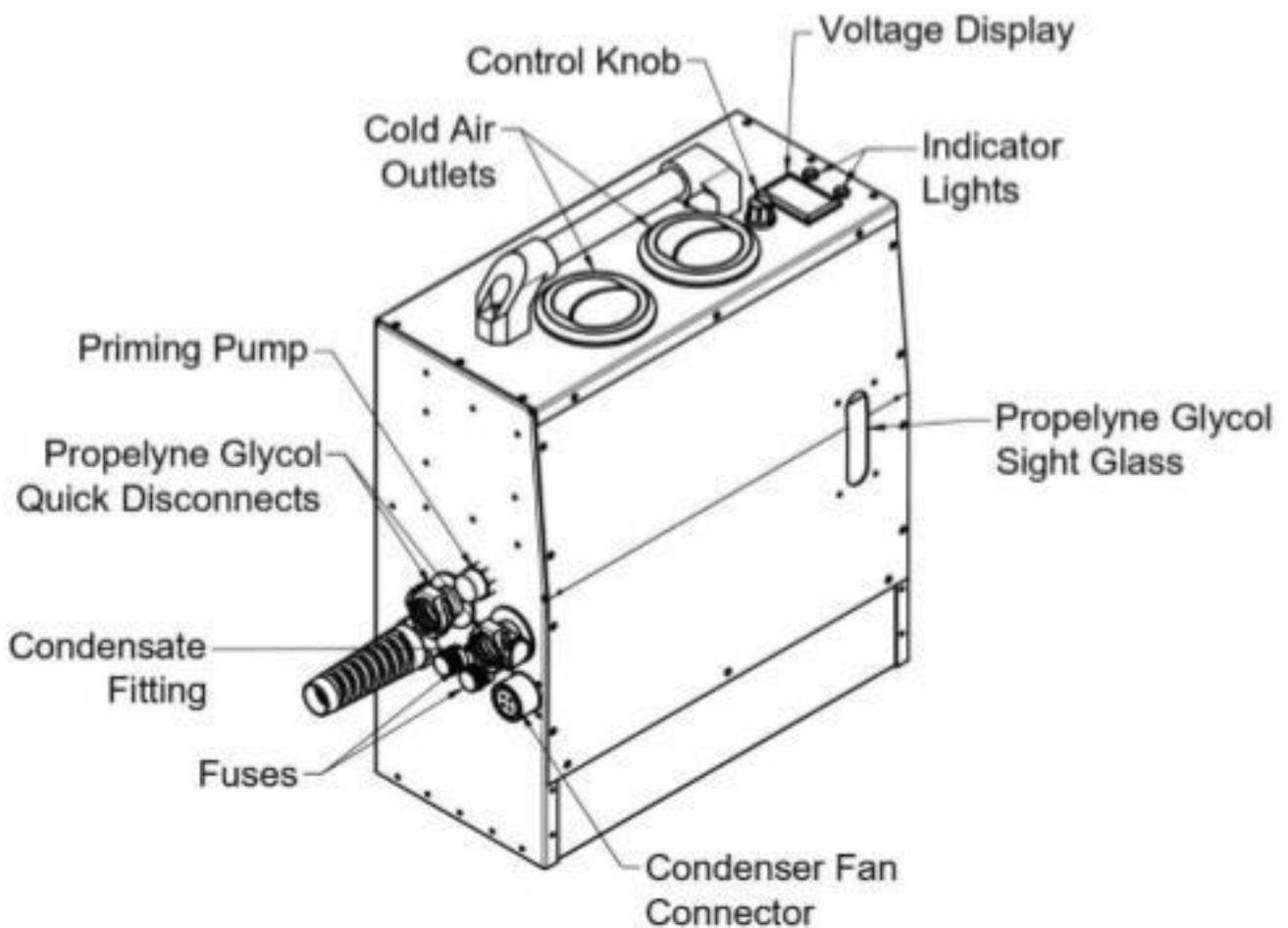

Condenser Module Overview

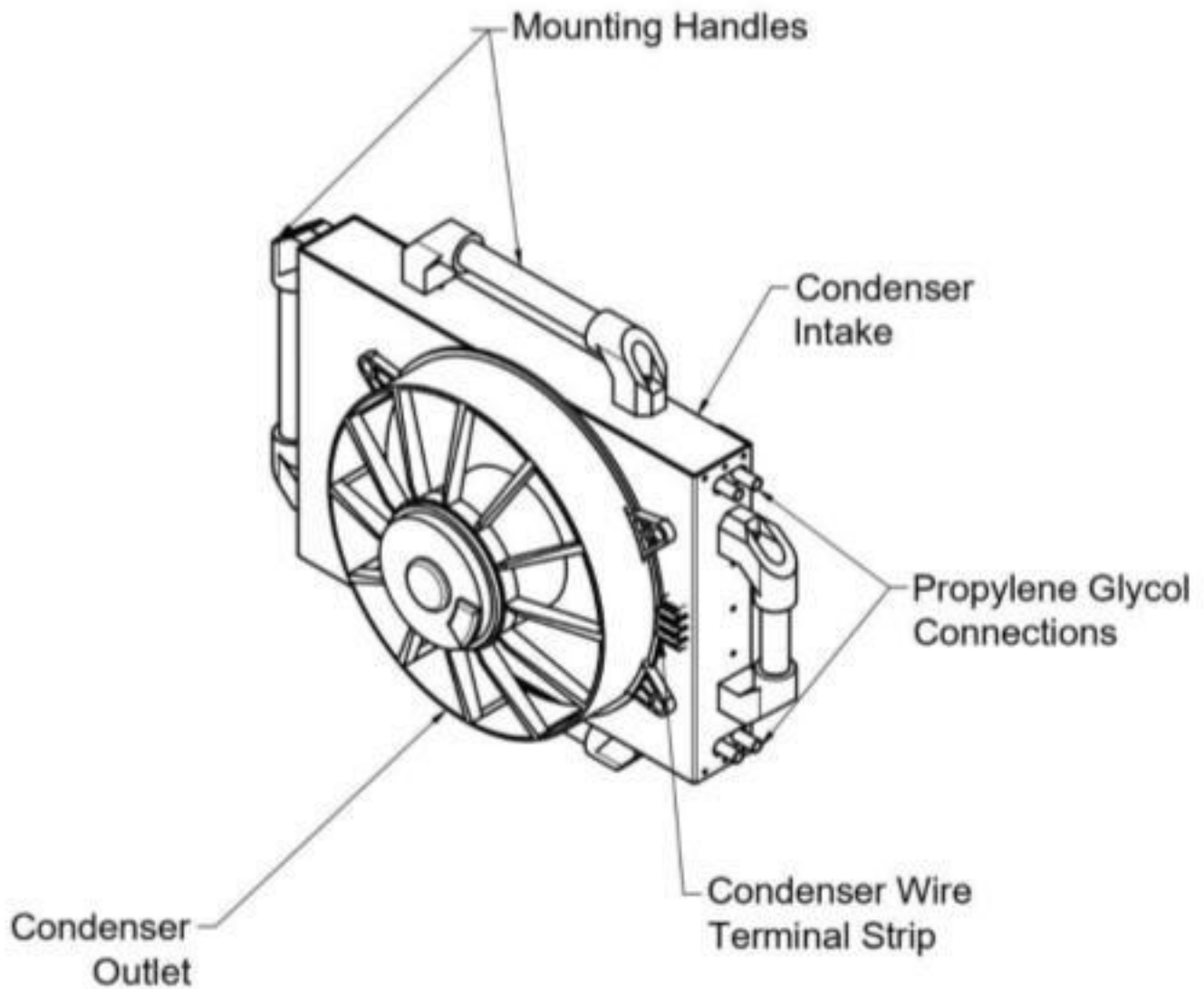

Safety Information

- **Electrical Safety:**
 - Ensure that the unit is plugged into the proper MS Plug that meets the voltage and current requirements specified in the user manual.
 - If the power cord or plug is damaged, discontinue use immediately and contact a qualified technician for repairs.
 - Use only the provided power cord and accessories.
 - Unplug the unit before cleaning or performing maintenance.
 - Do not run Sofie™ during engine start or shutdown.
 - In the event of a Alternator/Generator failure shut the unit off and remove power via breaker or remote solenoid switch.
- **Installation Safety:**
 - When installing the unit, ensure that it is placed on a stable and level surface to prevent tipping and is properly secured.
 - Use caution when handling the unit and its components, as they may be heavy or have sharp edges.
 - Do not block the airflow around the unit or obstruct the exhaust hose, as this may cause overheating or damage to the unit.
 - Ensure to follow the installation manual for proper install.
 - Verify that the propylene glycol level is visible on the sight glass and the cap is tight.
- **Gas Safety (R-134a):**
 - R-134a is a refrigerant gas used in the Sofie™ system. While it is generally safe when handled properly, it can pose risks if mishandled.
 - If you suspect a refrigerant leak, immediately turn off the unit and contact a qualified technician for repairs.
 - Never attempt to repair refrigerant leaks or recharge the system yourself. Only trained professionals should handle refrigerant-related tasks.
- **Ventilation Safety:**
 - Do not block the air intake or outlet vents.

Safety Information

- Propylene Glycol Safety:
 - While propylene glycol is generally considered safe and is even used in food and cosmetic products, it should still be handled with care. Use protective gloves and eye protection when dealing with propylene glycol solutions, particularly when handling large quantities or concentrated solutions.
- Leak Detection:
 - Regularly inspect the system for any signs of leaks, especially in areas where propylene glycol is circulated.

System Components

- **STANDARD COMPONENTS SUPPLIED BY PSA with Sofie™**

- **Installation Kit**

- Condensate Drain Feed Through P/N 55010 (Condensate Drain)
- Amphenol Electrical P/N 55100 (Female Power Plug)
- 4 ft. of 1/8 in. ID Silicone Tubing P/N 55011 (Condensate Drain Line)
- Tie Down Strap P/N 55020 (Securing Unit)
- (2) Tie Down Brackets P/N 55021 (Securing Unit)
- 10ft. of 3/8 in. Propylene Glycol Tubing P/N 52520
- 10ft. of 1/2 in. SnakeSkin P/N 52530
- (2) 3/8 in. Propylene Glycol Male Quick Disconnect P/N 51551
- 11ft. Condenser Fan Pigtail P/N 51480
- Sofie™ Main Unit P/N 51000
- Sofie™ Condenser Module P/N 51500
- Outside Air Aircraft Scoop Kit P/N 55200

- **OPTIONAL COMPONENTS SUPPLIED BY PSA with Sofie™**

- Condenser Outlet Shroud P/N 55205 (For Main Unit)
- 12v GPU Power Pack P/N 55101 (For Engine Off Operations)
- 24v GPU Power Pack P/N 55102 (For Engine Off Operations)
- 5 ft. Remote Extension Cord P/N 55111
- 10 ft. Remote Extension Cord P/N 55112
- Sofie™ Remote & 9 ft. cable P/N 55110

- **Additional AIRCRAFT INSTALLATION PARTS**

INSTALLER Direct- Aircraft Spruce Part Numbers- 877-477-7823

- 80 Amp Klixon Breaker- Recommended: P/N 11-08401 / Installers Discretion
- #6 AWG MIL-W-22759/16-06-9 P/N 11-14506 (24V Unit)
- #4 AWG MIL-W-22759/16-06-9 P/N 11-14504 (12V Unit)
- 5" Diameter Ducting P/N 05-30520 (If using intake scoop)
- 6" Diameter Ducting P/N 05-29824 (If Ducting Exhaust to Bulkhead)
- Rivets/ Hardware

- **Sofie™ Maintenance items**

- Propylene Glycol P/N 55500
- Wetting Agent P/N 55501
- Sofie™ Intake Filter P/N 51290

Operating Instructions

- Ensure the main power plug, wired remote, propylene glycol quick disconnects, fan/condensate pump wire, and condensate drain are connected before use.
- Verify the propylene glycol level is sufficient and the liquid lines are not kinked or restricted.
- GND setting is recommended for low rpm during taxi, pattern flight, and approach/ landing.
- If displayed voltage is low on remote during taxi, increasing engine rpm can stabilize voltage (1000 rpm recommended)
- FAN only runs the evaporator blowers for a low power setting that keeps airflow in the cabin

Note: Amperage draw increases with high ambient temperatures

Power Settings

During ground operation and taxi, power use is limited by the electrical power available from the alternator. Under less than ideal circumstances, lower power settings achieve more cooling than a maximum power setting. When the engine is at higher rpm in flight, higher power settings can be used.

Automatic Operational Sequences

- **TURN ON-** Unit must have power for at least 5 seconds to initialize before switched on. An automated turn-on sequence maintains low power "GND" for the first 30 seconds and then proceeds to the selected rpm/power setting within two minutes. Sofie™ will shut off if there is a low voltage or high temperature occurrence within the first 30 seconds of turn-on.
- **AUTO POWER-** This feature causes a reduction in power compared to the selected dial setting for an instance of low bus voltage (specifically at 12.0 volts or 24.0 volts), depending on the particular 12 or 24 volt model.
- **Orange LED Light-** for low voltage <12.0 / 24.0 VDC buss: - then if condition persists, reduces automatically to 1/2 power
 - or after 10 seconds, reduces to minimum power
 - ramps back up after 2 minutes
 - for low voltage at minimum power settings, shuts down with orange alarm light.
- **Yellow LED Light-** for overheating, usually during ground operation (300 psi) - shuts OFF for 30 sec, then starts on LOW for 2 minutes - ramps back up after 2 minutes - for high pressure at <70% power, shuts down with yellow light.
- **Manual shut down-** When Off is selected, the condensate pump and condenser blowers run for 25 seconds to purge the unit and then the system powers off.
- **System Reset-** To reset the system: select OFF, pull the associated breaker, wait 5 seconds, push the breaker in, wait 5 seconds, then turn the system back on.

Maintenance & Care

- Clean the evap intake air filter to maintain optimal performance annually or every 100 hours of use.
- Maintain glycol level above $\frac{1}{4}$ of sight glass.
- Check the condenser intake screen at the scoop (if applicable) for obstructions regularly.
- Check for any obstructions in the condenser exhaust and remove them if necessary.
- Wipe down the unit with a damp cloth as needed.
- Store the unit in a dry place when not in use.

Troubleshooting

Troubleshooting for resolving any issues that may arise while operating the Sofie™ Air Conditioning System. Below are some common problems you may encounter, along with possible solutions:

- **Unit Does Not Turn On:**
 - Ensure that the power cord and remote are securely plugged in.
 - Inspect the power cord and remote wire for any signs of damage. If damaged, contact PSA.
 - Ensure that the breaker has not popped. If it has, push it back in and monitor the unit closely to make sure everything is functioning normal.
- **Inadequate Cooling:**
 - Check glycol to ensure there is adequate level
 - With power on the unit, not running, hold priming button with the fill cap off to verify that the pump is operating.
 - Check for kinks or restrictions along the glycol lines to ensure there is proper flow.
 - Check that the air filter is clean and not clogged with dust or debris. Clean or replace the filter if necessary.
 - Verify that the condenser exhaust hose is properly installed and not obstructed, allowing hot air to exhaust outside of the cabin.
 - Verify that the air intakes are properly installed and not obstructed, allowing air into the unit.
- **Unit Shuts Off Unexpectedly:**
 - (Yellow Temp LED) Check if the unit is overheating. Ensure that there is sufficient condenser airflow in & out of the unit and that the vents are not blocked.
 - (Orange Volt LED) check to see sufficient airflow in & out of the unit and ensure that you are operating in the proper particular setting at the proper engine RPM.
 - For excessively high ambient temperatures, reduce power setting to prevent automatic shutdown.
 - Inspect the power cord, remote wire, and plug for any signs of damage. Replace if necessary.
 - Reset the unit by resetting the breaker (Check Automatic Operational Sequences for instructions).

Troubleshooting

- Unusual Noises or Vibrations:
 - Check for any damaged parts, such as fan blades.
 - Ensure that the unit is placed on a level surface to prevent vibrations.
 - Clean the unit's fan blades and motor to remove any accumulated dirt or debris that may be causing the noise.
 - If the problem persists, contact customer support for further assistance.
- Remote Control Malfunction:
 - Make sure the remote control cable is fully connected.
 - Check for any damage to the remote control or the cable.
 - If the remote control still does not function properly, contact customer support
- Water Leakage:
 - Check for any blockages in the unit's drainage system, such as the condensate drain. Clear any obstructions.
 - Ensure that the unit is installed level to allow proper drainage of condensate.
- Glycol Leakage:
 - Make sure hose connections are tight and fully attached to fitting.
 - Leakage between quick disconnects are a result of either debris on the o-ring, which requires a simple cleaning with a towel to clear it, or visible damage to the o-ring. If the o-ring is damaged contact PSA for a replacement.

If you encounter any issues that cannot be resolved using the troubleshooting steps provided, please contact customer support for further assistance. Provide PSA with detailed information about the problem and any troubleshooting steps you have already taken.

Technical Specifications

Main Module

14 VDC Model: 8,000 BTU
35-75 Amperes- Adjustable

28 VDC Model: 13,000 BTU
25-65 Amperes- Adjustable

Cold Air Output: 120 CFM

100 Amp Alternator Recommended

Weighs 28 Lbs.

Note: All dimensions are in inches

Front View



Rear View

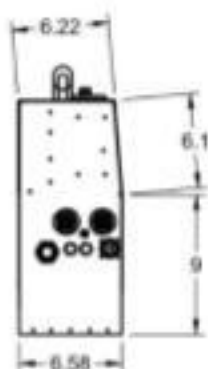
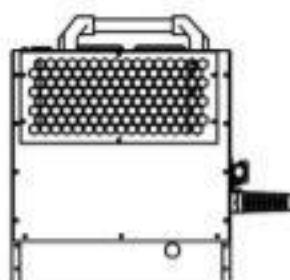

Technical Specifications

Remote

Remote Cord Length: 9 ft.

Weight: 8.5 oz.

Optional 5 ft. Extension Cord Weight: 3 oz.

Optional 10 ft. Extension Cord Weight: 5 oz.

Note: All dimensions are in inches.



Technical Specifications

Condenser Module

Weight: 10 Lbs.

Note: All dimensions are in inches.

Front View

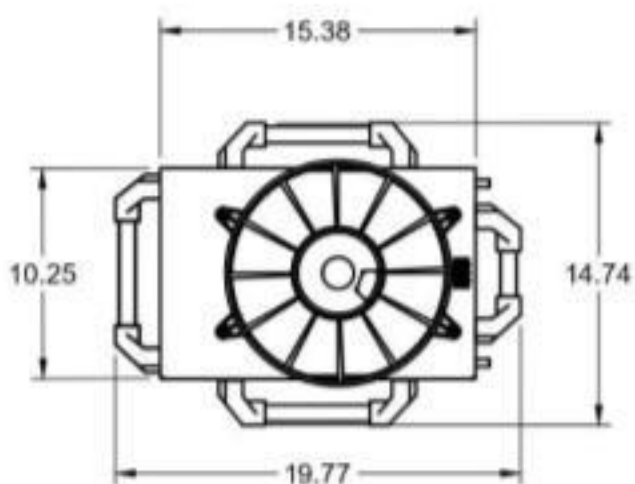

Rear View

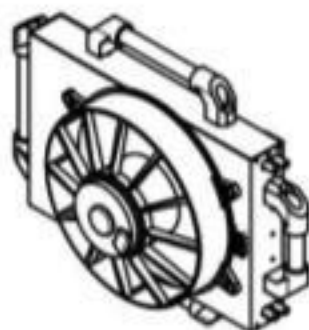
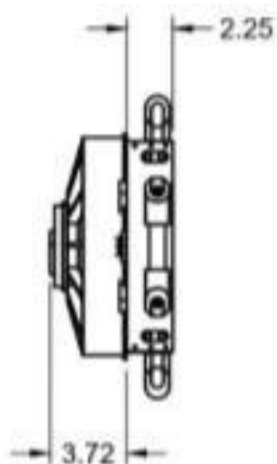
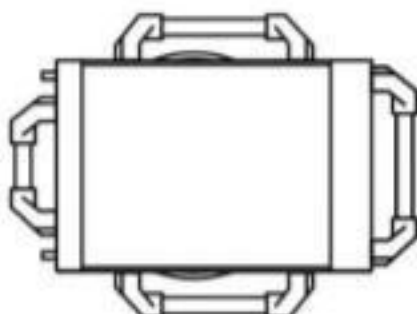

Warranty Information

The Sofie™ unit comes with six months labor (prior approval required), 1 year parts from date of purchase. Covers defects in materials and workmanship in this product. Continued operation of defective unit that is not cooling, indicating possible loss of refrigerant, can void warranty.

Contact Information

For questions or assistance, please contact:

Peter Schiff Aero, Inc.

4400 Log Cabin Lane

Cookeville, TN 38506

Airport Identifiers: K8A3 or TN80

coleschiff@peterschiffaero.com

Tel: 931-537-6505

Cell: 931-284-1534

Fax: 931-537-6495

Visit us at www.PeterSchiffAero.com